

LEONEAMERICA ORTHO NEWS



TREATMENT WITHOUT THE HASSLE

- NO COMPLIANCE
- NO RISK OF OVERTREATMENT
- NO OPERATOR DEPENDENCY



TABLE OF CONTENTS

- 3 Leaf Expander: New Horizons of Maxillary Expansion in Interceptive Orthodontics
Lanteri, C; Lanteri, V; Gianolio, A; Berretta, M; Cherchi, C.
- 17 Leaf Series Expanders
- 18 Expanding of Focus: Pediatric Orthodontics and Sleep Apnea Devices
- 20 Welcome to Baltimore: American Academy of Dental Sleep Medicine Annual Session
- 21 Ceramic Bracket
- 22 Leone GoTo1 (Class II Corrector)
Leone Technical Dept., Division of Orthodontics
- 30 Why Choose Us: Applications of LeoneAmerica Products
- 31 Leone Certified Labs: LeoLab USA
- 32 Where To Find Us: LeoneAmerica Collaborations
- 33 Bringing It All Together: 2018 AAO Washington DC

A0620-15 RAPID PALATAL EXPANDER

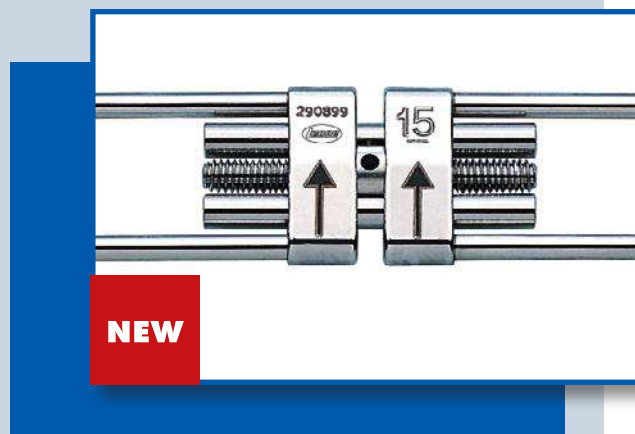

The best-selling rapid expander line has expanded to include a 15mm model! Sizes 8mm, 9mm, 11mm, 13mm, 15mm now available

A0556-00 CLASSIC SWIVEL KEY



This classic design is a patient favorite among activation keys, and is now available in packs of 10 through LeoneAmerica Dental Products, Inc.

LEAF EXPANDER®

New Horizons of Maxillary Expansion in Interceptive Orthodontics

Lanteri C., Lanteri V., Gianolio A., Beretta M., Cherchi C.

Original title: "LEAF EXPANDER® I nuovi orizzonti dell'Espansione Mascellare in Ortodonzia Intercettiva",

Leone Bolletino number 100, October 2017.

Introduction

Transverse maxillary deficiency is an often-observed feature of both dental and skeletal malocclusions; it is generally characterized by posterior crossbite and/or by upper arch dental crowding. The frequency of crossbite in the population usually ranges from 6% to 30%, according to different studies. The probability of a crossbite spontaneous self-correction as a result of the interruption of etiological factors, like bad habits, is quite low (from 0% to 9%). Meanwhile, it is well-known that the chance of obtaining an expansion of maxillary bone diminishes with growth and aging. Therefore, the necessity of an early and accurate diagnostic evaluation is fundamental; it allows the classification of patients according to their type of maxillary deficit and the application of the most appropriate clinical protocols. From the Guideline on Management of the Developing Dentition and Occlusion in Pediatric Dentistry, published in 2014, by the American Academy Of Pediatric Dentistry "[...] Crossbites should be considered in the context of the patient's total treatment needs. [...] Early correction of unilateral posterior crossbites have been shown to improve functional conditions significantly and largely eliminate morphological and positional asymmetries of the mandible.". *Clinical Practice Guidelines in Dentistry, published in Jan 2014 by the Italian Ministry of Health, claims that "[...] Among transversal discrepancies, those related to a maxillary contraction show a high degree of frequency - data which becomes even more relevant when defining palatal contraction. A head-to-head [end-to-end] occlusal/transversal relationship is also taken into account".*

Several authors, in the last several decades, have created devices for maxillary expansion, with different technical and biomechanical features, concerning the amount of expansion achievable and the type of modifications which they could produce (orthodontic, orthopedic or mixed).

However, all these techniques had in common the application of forces which acted in a vestibular direction on "pillar-teeth", that determine morphological reactions on the jawbones, whose effects are mainly linked to three factors:

- a) the age of the patient (growing or adult patients)
- b) the kind and type of force being applied ('light', as in orthodontics, or 'heavy', as in orthopedics)
- c) the time and length of its action (continuous, discontinuous, or intermittent).

In recent times our attention has been focused on the clinical protocol and effectiveness of LEAF EXPANDER, a reloadable expander with NICKEL TITANIUM Memoria® leaf springs, created in 2013 as an evolution of its predecessor, the Slow Maxillary Expander (S.M.E.), whose reloadable component was a compressed coil spring made of steel (see C. Lanteri, F.Francolini - 2005).

LEAF EXPANDER (also L.E.) is a customized orthodontic device, which produces a jawbone expansion primarily through dental-alveolar remodeling, by the means of a continuous light force application, with predetermined intensity and direction, and with a predictable amount of dislocation (Lanteri C., Lanteri V., Gianolio A., Beretta M., Cherchi C., Franchi L., A new way for no compliance palatal expansion: The Leaf Expander Journ Clin Orthod 2016).



Figure 1 L.E. with 6mm screw, characterized by a double Nickel Titanium leaf spring

LEAF EXPANDER: TECHNICAL FEATURES

LEAF EXPANDER (L.E.) is made up of a metallic structure in Cr-Co steel with a midline screw which, when activated, compresses two or more leaf springs in Nickel-Titanium (Figure 1).

The L.E. structure appears totally similar to a common rapid or slow palatal expander, but is different in the characteristics of its active component and for the method of action. The screw does not directly act on the supporting teeth, but rather functions to compress Nickel-Titanium leaf springs which, when deactivated, recover the original shape, causing a calibrated expansion of the upper dental arch.



Figure 2 - Example of expansion achieved with L.E. at 450 gr/6 mm, in four months.

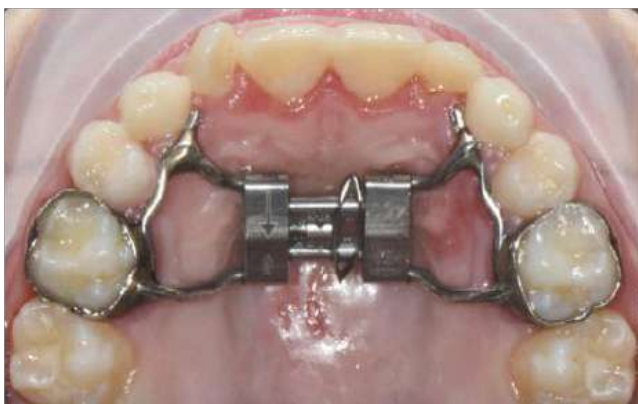

Figure 3

The L.E. biomechanical feature is markedly different from all the other fixed orthodontic devices used to achieve a slow maxillary expansion, such as the Gosgharian Bar, Ricketts' Quad-Helix or Ni-Ti Expander. Furthermore, the L.E. gathers some features which we could consider as optimal for a fixed expansion orthodontics device, such as:

- an extremely limited number of intra-oral re-activation sessions;
- ease of activation;
- absence of pain, even in the first phases of active expansion;
- control of vestibular tooth inclination by means of a corporeal movement in the vestibular direction, assuming the device is accurately modelled at the neckline-level for the highest possible number of teeth, with extensions to permanent canines (if present in the dental arch);
- high-level of control for the progression of movement;
- impossibility of device deactivation due to the action of occlusal forces;
- development of light, predetermined and continuous forces;
- possibility of precise regulation of the movement;
- absence of overtreatment risks.

The most common structural features of the L.E. entail the use of 2 bands, usually positioned on the second deciduous molars or on the first permanent molars, with possible variations and adaptations according to specific clinical situations.

In order to ensure optimal stability and effectiveness, the lateral metal frame must be well-modeled and adhere to the lingual neckline of posterior molar elements, while connective arms between the midline screw and lateral components must remain detached from palatal mucosa (about 2.5 mm) to avoid any risk of impingement.

When upper canines are present in the upper dental arch, two well-modeled extensions are applied that make ongoing contact with their lingual surface, both to increase the expansion effect in the anterior area and to improve the device stability.

The L.E. is bonded with a fluoride-releasing glass-ionomer-cement. Many studies have pointed out that, in case of a maxillary transversal deficit, the discrepancy is usually less than 5mm. Thus, the 6mm screw allows for treatment of the majority of the clinical cases. For larger deficits, the 9 mm screw could be required. Both with 6 mm and 9 mm screw each screw activation causes a device expansion of 0.1 mm (meaning 1 mm every 10 activations).

Generally, the 450 gr L.E. is used on patients with deciduous/mixed dentition, while the 900 gr version is preferable when the patient has already completed his permanent dentition.

The choice between 6 and 9 mm screw should be based on the type of discrepancy to be resolved: in the case of unilateral crossbite the 6 mm screw should be sufficient while in bilateral crossbite the 9 mm option is recommended. In the case of 6 mm screw, the device is made up of two leaf springs. Normally 10 activations in 4 weeks are performed, reaching the maximum number of activations (30) in 12 weeks (see Protocol 1).

The 9 mm device model, with three leaf springs, allows a maximum expansion with 45 activations, with 15 activations in 6 weeks and 45 activations reached in 18 weeks (see Protocol 1).

PROTOCOL 1











Protocol 1 proposes the management of screw activation in three sessions during the whole cycle of treatment. Therefore, it is useful to distinguish between the 6 mm screw (both in 450 gr, 900 gr) and the 9 mm one (both 450 gr and 900 gr). The descriptions of activation sessions can be found in Table 3.

PROTOCOL 2

Protocol 2 proposes the complete reactivation of the screw in a single session and is suggested in the case of non-cooperating patients who need sedation or when the needs (both logistical or organizational) of the patient and/or of the dental practice, require low frequency programming. A complete reactivation usually would verify after 18 weeks for the 6 mm screw and after 26 weeks for the 9 mm one. In these cases to make the procedure more comfortable for the patient, the reactivation could be subdivided in three steps, with 10 or 15 turns according to the size of the screw used, interspersed with pauses of 2 or 3 minutes.

Note: Protocol 1 represents the best choice in most cases. In both Protocols 1 and 2, it is necessary to execute the exact number of activations to achieve re-compression of the leaf springs, verifying the presence of a small space among them; please consider that further activations would actually produce “heavy” forces, similar to the ones required for rapid expansion.

Table 1
AVAILABLE LEAF EXPANDER®

	 11 mm	 4 mm	 arms	 body			activation turns for maximum expansion limit
					6		
					450		
					2 springs		
					450 g approx		
			1,5 mm	12 mm	6 mm	0,4 mm	30
					6		
					900		
					2 springs		
					900 g approx		
					9		
					450		
					3 springs		
					450 g approx		
			1,5 mm	12 mm	9 mm	0,4 mm	45
					9		
					900		
					3 springs		
					900 g approx		

Tab. 3- Protocol 1

Screw	Leaf delivery	I Treatment session	II Treatment session	III Treatment session
6 mm A2703-06 A2704-06	Spring unlock-0 activation	10 activations <i>After 6 weeks</i>	10 activations <i>After 4 weeks</i>	10 activations <i>After 4 weeks</i>
9 mm A2703-10 A2704-10	Spring unlock-0 activation	15 activations <i>After 8 weeks</i>	15 activations <i>After 6 weeks</i>	15 activations <i>After 6 weeks</i>

CLINICAL CASES

CASE 1 - Margherita, 9yo

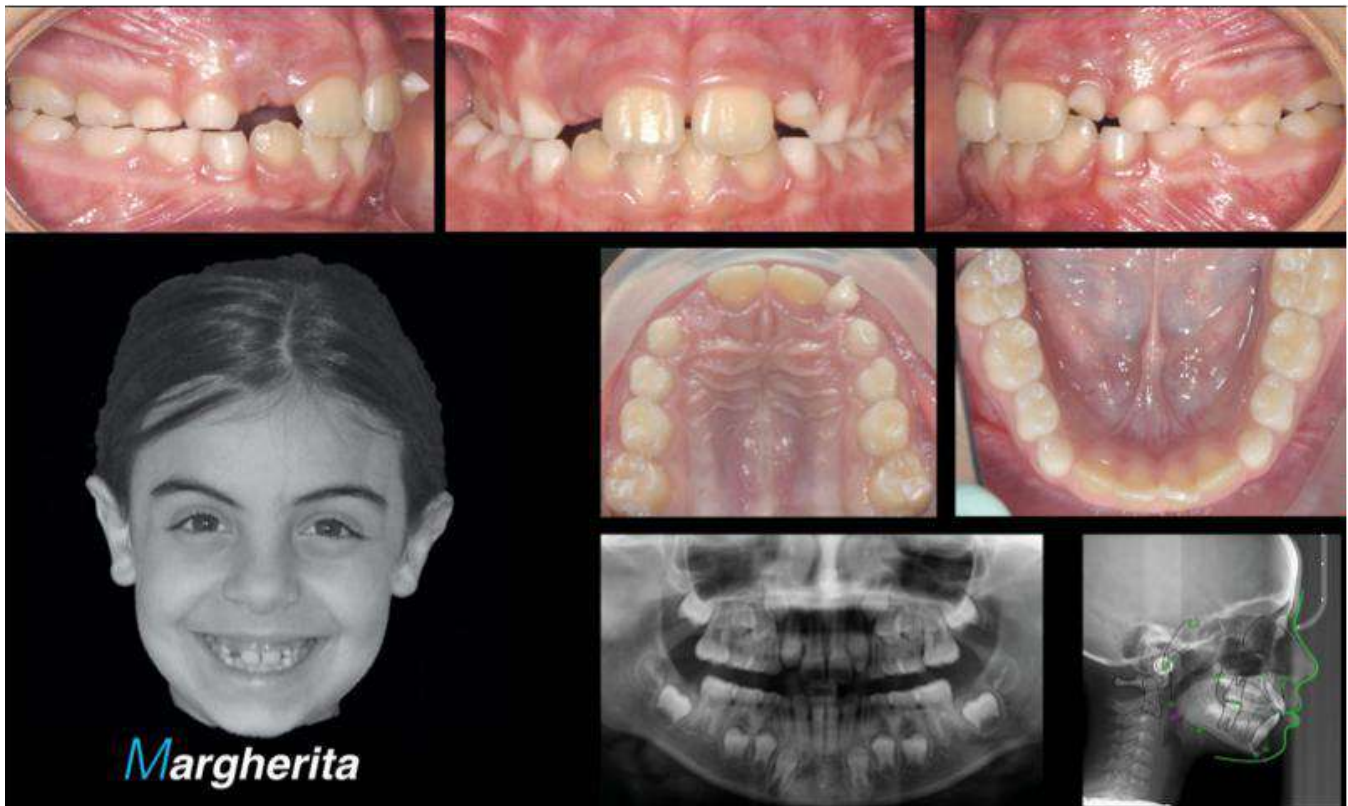

Figure 4- Class I malocclusion with transverse maxillary constriction. Unilateral crossbite on the right side, resulting from the mandibular shift.

Table 4- Start of Treatment: the 6 mm 450 grams Leaf Expander screw is selected.



Figure 5- Protocol of Leaf Expander® 6 mm screw activation



Figure 6- Thirty (30) activations have been carried out, subdivided into three sessions of 10 activations each.



Figure 7- Clinical results of the expansion protocol in the upper dental arch (C/C +7,5 mm - E/E +6 mm - 6/6 +4 mm)

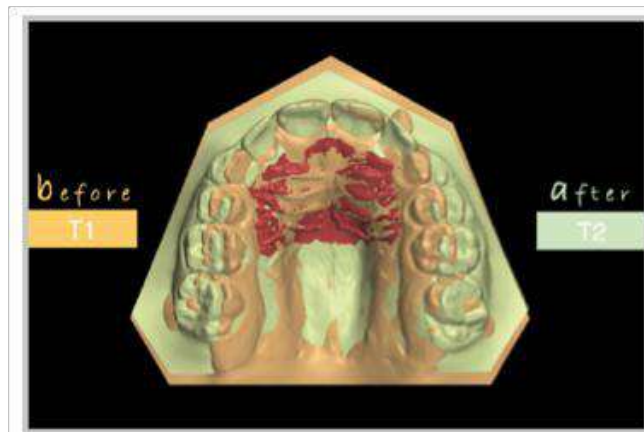

Figure 8- Clinical results of upper dental arch expansions are evaluated with superimposition of 3D models and measurements taken before (T1) and after (T2) the expansion.



Figure 9 - Modifications produced in the lower dental arch after maxillary expansion (6/6 -0,62 mm - C/C +0,95 mm)

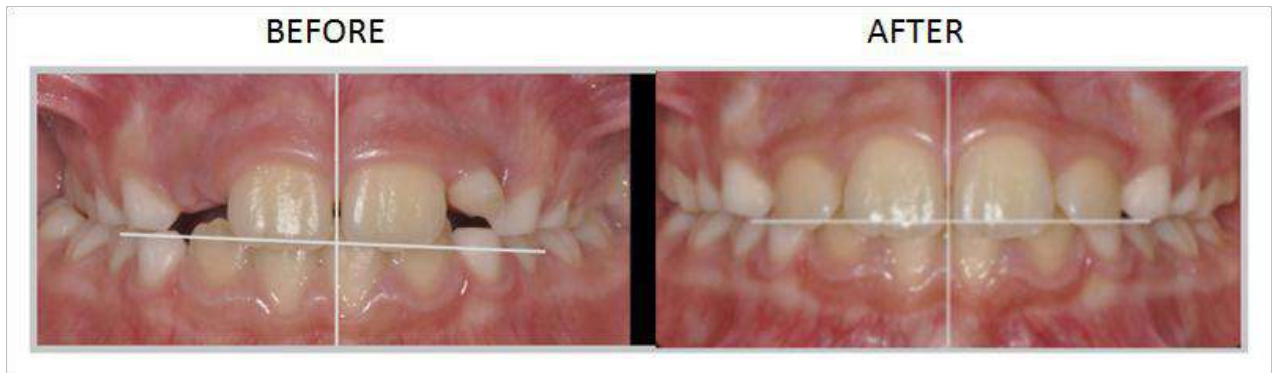

Figure 10 - Comparison between beginning and end of the active expansion phase (correction of crossbite, the occlusal plane, and the midline)

CASE 2 - Ludovica, 12 yo

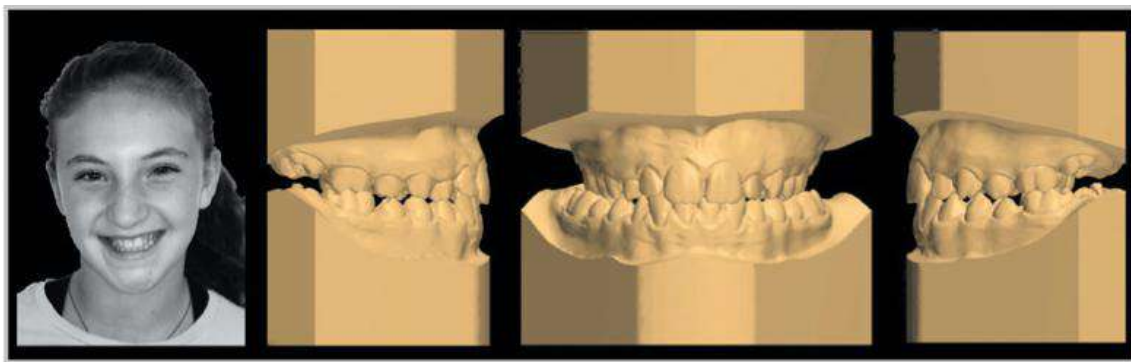

Figure 11- Class I malocclusion with a tendency towards class III. Maxillary transverse deficiency with bilateral crossbite. Permanent dentition with space deficit for 1.3 and inclusion of 2.3.

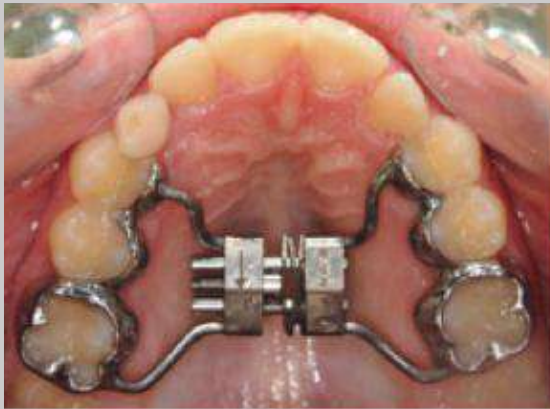

Figure 12: Panoramic X-ray

Table 5- Start of Treatment: the 9 mm 450 grams screw is selected.

Protocol 1
LEAF EXPANDER®
9 mm – 450 gr

15 activations each 6 weeks
(starting from the VIII week)





	LEAF EXPANDER® 9 mm DELIVERY
	AFTER 4 WEEKS No activations performed
	AFTER 8 WEEKS 15 activations performed
	AFTER 6 WEEKS 15 activations performed
	AFTER 6 WEEKS 15 activations performed TOTAL No. 45 activations
	AFTER 6 WEEKS Completed expansion

Figure 13 - Clinical protocol for Leaf Expander® 9 mm screw activation.



Figure 14 – Before treatment.



Figure 14, 15 - Results of upper dental arch expansion.

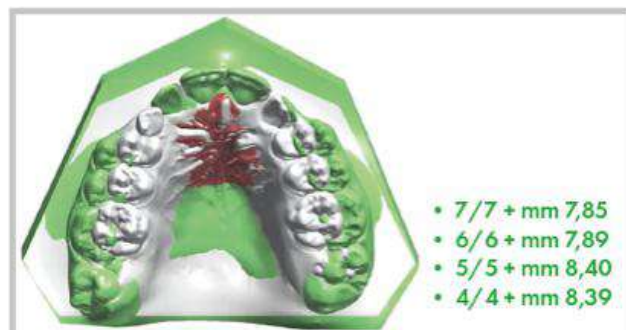

Figure 16 – Superimposition of models: results of upper dental arch expansion.

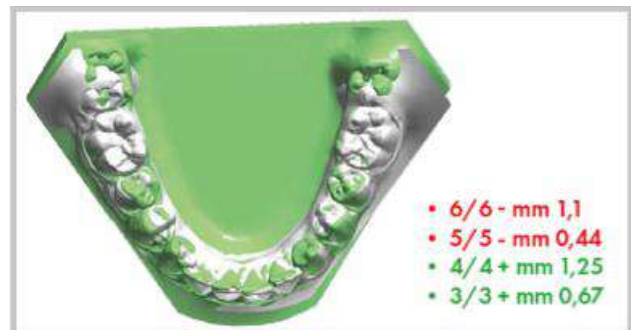

Figure 17– Superimposition of models: modification induced in the lower dental arch.

CASE 3 - Aurora, 9yo



Figure 18 – Hyper-divergent skeletal Class III malocclusion with a maxillary transverse deficiency and open bite.



Figure 19 - Upper and lower dental arch before treatment



Figure 20 – Mandibular shift due to the premature contact of the deciduous canines before treatment.

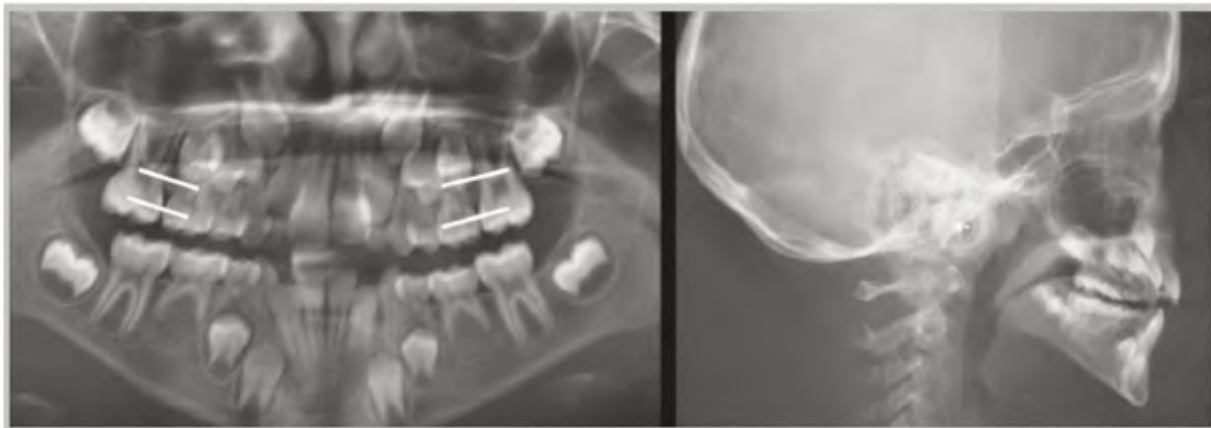

Figure 21 - Panoramic X-ray.

Table 6 - According to the clinical L.E. expansion protocol, the 9 mm screw is chosen for the correction of the bilateral crossbite. Considering the presence of skeletal hyper-divergence with open bite, the device has been integrated with a Haas-type palatal acrylic plate. Since the forces are distributed on a wide surface, it is advisable to utilize the 900 gr screw.

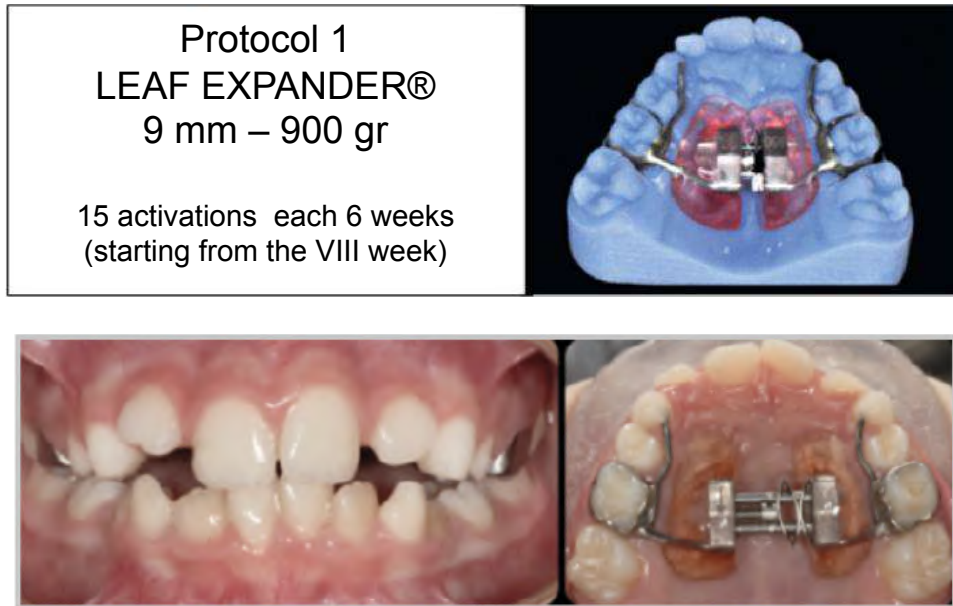

Figure 22 - Correction of crossbite has been obtained at the end of the active expansion thanks to maxillary bone remodeling. The treatment results also entail permanent molars, which were not included in the device.

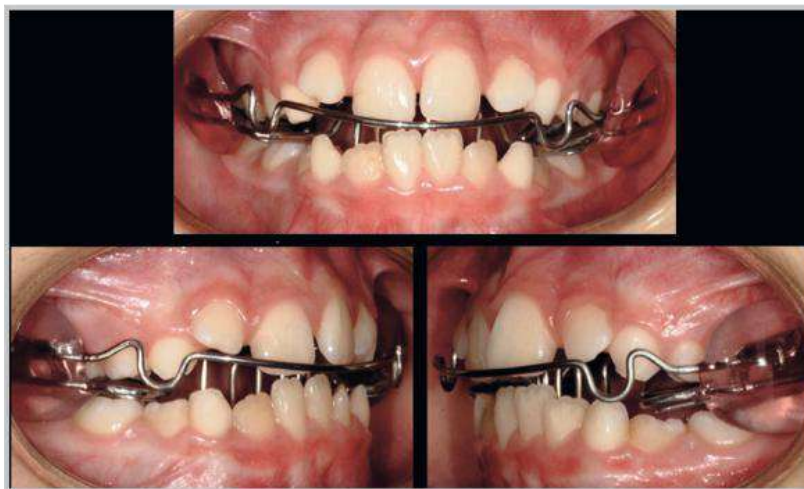

Figure 23 - After the Leaf Expander was removed, a period of Functional orthodontic therapy followed (Cervera appliance with palatal crib), to finalize the control of the open bite.



Figure 24 – End of treatment, results after 18 months of interceptive therapy (Leaf Expander plus Cervera Appliance).



Figure 25 - Comparison between beginning and end of treatment.

LEAF EXPANDER'S "TWO IN ONE" ORTHOPEDICAL PROTOCOL

According to recent studies, which are currently being published, the comparison between rapid expansion and expansion achieved through the use of the LEAF EXPANDER shows that the first is much more effective regarding the augmentation of nasal airway patency (Gualandi G., Dento-skeletal changes after rapid vs slow maxillary expansion on deciduous teeth: rct with CBCT, MS Thesis - Università di Varese, 2017). From this observation, in order to enhance corrective performance in mouth-breathing subjects with maxillary transverse deficiency, the "Two in One" protocol has been developed.

The LEAF EXPANDER can be used also to achieve a rapid palatal expansion simply by modifying the activation protocol; in this case the cooperation of the subject is necessary. The device is delivered to the clinician with completely compressed leaf springs, in keeping with previous protocols. Further activations (3 mm for the 6 mm screw, for a total of 30 activations; 4.5 mm for the 9mm one, for a total of 45 activations) would prompt the direct action of the screw on the supporting teeth, producing orthopedic forces.

For the correct employment of the "Two in One" protocol it is necessary to bear in mind that through 10 activations, 1 mm of screw expansion is obtained. Therefore, to obtain an expansion of 0.2 mm per day, as suggested by the overarching majority of authors, 2 activations per day should be executed, both with the 6 mm and 9 mm screws.

Once the orthopedic phase is finished, the expansion would go on spontaneously with light forces (450 grams or 900 grams) thanks to the deactivation of the leaf springs.

The "Two in one" protocol can be quite useful to achieve the palatal expansion of a border-line aged patient, in the case of a missed fracture of the palatal suture, the deactivation of the screw could be executed, bringing the leaf springs back into the light forces range of action, and recovering the function of slow expansion.

EXAMPLE OF LEAF EXPANDER® "TWO IN ONE"



Figure 26 - Leaf Expander custom made with 6 mm – 450 gr screw.

AFTER 30 ACTIVATIONS



Figure 27 - Leaf Expander after orthopaedical activation. After 30 activations, 3 times per day (0.3 mm).

TREATMENT BEGINNING

AFTER 30 ACTIVATIONS



Figure 28 - Fracture of the palatal suture obtained through rapid activation of LEAF EXPANDER: 30 activations, 2 times per day for 15 days (0,2 mm per day).

4 MONTHS AFTER THE COMPLETED EXPANSION



Figure 29 - In the phase following the active rapid expansion, the deactivation of the leaf springs takes place, with light and continuous forces.

WORK IN PROGRESS

The **LEAF EXPANDER's** new technology respects the principle of delivering light, constant and directionally predetermined forces, without any intervention either from the patient or from the orthodontist.

Figure 30-SELF EXPANDER®
6mm 450 gr.



TREATMENT BEGINNING



Figure 31 - 9 mm - 450 gr device.

AFTER 1 MONTH



Figure 32 - Once the ligature securing spring compression is removed, the device produces progressive action without needing any reactivation.

AFTER 2 MONTHS



Figure 33 - Follow up (8 weeks).

AFTER 3 MONTHS



Figure 34 - Once the programmed expansion is reached, the device ceases its action.

CONCLUSIONS

Several studies have pointed out significant changes in maxillary transverse diameters in all age groups, as well as orthopedic effects in younger subjects when early treatment is performed with light forces on still-active sutures.

Clinical results proved the effectiveness, the efficiency, and the ease of use of the LEAF EXPANDER device in the correction of transversal maxillary deficits in growing patients, with methods that do not require active patient compliance and any particular skill of the operator. The LEAF EXPANDER can be used also for the treatment of patients with a highly-probable full maturation of the palatal suture, or even as an alternative to surgically-assisted expansion in adult patients.

The observed advantages of LEAF clinical employment are:

- ease of activation
- immediate visual validation of activation

- safety of use
- no need for active patient compliance
- mostly corporeal dental movement
- pre-determined, light, and continuous forces
- predictability of results

Effects are clinically and radiographically superimposable to those achieved through the use of rapid maxillary expander. Therefore, in conditions disadvantageous for the employment of a traditional expander design, the LEAF EXPANDER does constitute an optimal alternative.

Upcoming research, based on a large sample in the first stages of clinical trial, are oriented toward comparisons to other expansion devices, and would benefit from measuring on digital models, and analyses of both frontal and lateral radiography and CBCT scans.

REFERENCES

1. Beretta M., Gualandi G. Maxillary expansion with Leaf Expander®: a preliminary longitudinally study on cone-beam computed tomography in growing patients Atti 93° Congress of European Orthodontic Society (2093SP) Montreux (Switzerland) June 2017
2. Beretta M., Lanteri C., Lanteri V. Effects of the new Leaf Expander® on the transverse dimensions of the maxilla: a preliminary longitudinally study on cone-beam computed tomography in growing patients Atti 46° Intern. Congr. SIDO, Milano, 29-31 Ottobre 2015
3. Farronato GP, Cordasco G, Farronato D, Esposito L, Briguglio E. The transverse sagittal maxillary expander J Clin Orthod 2007Jul;41(7):387-914. Gianolio A., Beretta M., Lanteri C., Lanteri V., Rapid and slow maxillary expansion: a postero-anterior cephalometric study World Journal of Orthod. Vol. suppl. 7th Int. Orth. Congress Sydney 2010
5. Gianolio A., Lanteri C., Lanteri V., Cherchi C. A new device for calibrated maxillary expansion Ortho News Vol 1/38 pag.1-10 2015
6. Gianolio A., Lanteri C., Lanteri V., Cherchi C. Un nuovo dispositivo per l'espansione lenta del mascellare superiore: l'espansore riattivabile con molle a balestra in nichel-titanio Boll. Inform. Ortod. 93:2014
7. Gianolio A., Lanteri V., Chierchi C. Rapid and slow maxillary expansion: a postero-anterior cephalometric study European Journal of Paediatric Dentistry Vol 15/4-2014
8. Gualandi G., Dento-skeletal changes after rapid vs slow maxillary expansion on deciduous teeth: rct with CBCT Tesi di Specializzazione in Ortognatodonzia - Università di Varese 2017
9. Lagravere MO, Major PW, Flores-Mir C: Skeletal and dental changes with fixed slow maxillary expansion treatment: a systematic review J Am Dent Assoc 2005 136:194-199
10. Lanteri C., Lerda F., Francolini F. L'espansore Lento Ammortizzato (E.L.A.): un nuovo apparecchio di espansione mascellare Boll. Inform. Ortod. Firenze 4: 22-28 2005
11. Lanteri C., Beretta M., Lanteri V. L'espansore lento ammortizzato (E.L.A) Boll. Inform. Ortod. 79:11-20 2007
12. Lanteri C., Beretta M., Lanteri V. L'utilizzo dell'E.L.A. nell'espansione mascellare Dent. Trib.III, 7:6-12 2007
13. Lanteri C., Lanteri V. La gestione biologica del mascellare superiore in early treatment: diagnosi, prevenzione e terapia precoce in età evolutiva. Atti Congresso AIFO - Associazione It. Funzionalisti Oro-facciali, Firenze 28-29 Ottobre 2016
14. Lanteri C., Lanteri V., Beretta M., Gianolio A., Procedura clinica di espansione del mascellare superiore: un caso esemplificativo Italian Dental Journal ISSN 1970-7428 ottobre 2016
15. Lanteri C., Lanteri V., Gianolio A., Beretta M., Cherchi C. Lanteri C., Espansione del mascellare superiore con il Leaf Expander® Dental Tribune - Anno XII n°6 pag. 20-21 Giugno 2016
16. Lanteri C., Lanteri V., Gianolio A., Beretta M., Cherchi C., Franchi L., A new way for no compliance palatal expansion: the Leaf Expander® Journal of Clinical Orthodontics volume 50: number 09: 552-560 2016
17. Lanteri V., Cambiamenti tridimensionali del mascellare superiore dopo espansione con Leaf Expander® in un campione di pazienti in età evolutiva: Valutazione mediante sovrapposizione di modelli digitali e di CBCT Tesi di Dottorato di Ricerca in Scienze Odontostomatologiche Università di Milano, XXIX Ciclo, 2017
18. Lanteri V., Gianolio A., Beretta M. Cambiamenti dento-alveolari mascellari e mandibolari dopo espansione palatale con Leaf Expander® in pazienti in crescita: studio pilota/upper and lower dento-alveolar modifications after palatal expansion using the Leaf expander in growing patients: a pilot study Atti 47° Intern. Congr. SIDO, Firenze, 13-15 Ottobre 2016
19. Lanteri V., Lanteri C., Sfondrini M.F. Un nuovo apparecchio di espansione mascellare: l'espansore lento ammortizzato Atti IX Conv. S.I.O.C.M.F. Lombardia Nembro (Bg) 2006
20. Lerda F., Lanteri C., A new appliance for maxillary expansion: E.L.A. (Espansore Lento Ammortizzato) World J. Orthod Vol 6 suppl. 6th Int. Orth. Congr. Paris pag 273 2005
21. Mobrìci P., Beretta M., Lanteri V., Lanteri C., Caprioglio A., Dental skeletal and periodontal changes in adult patients treated with a slow maxillary expander, Atti 89° Congress of European Orthodontic Society (Free Topics SP 251 pag. 175) Santiago de Compostela June 2012

NEW



The **MEMORIA®** Leaf Spring and Leaf Self Expanders are an evolution in the design of previous spring-loaded expanders. These innovative solutions rely on the flexible properties of nickel titanium springs to release calibrated and constant forces throughout treatment, providing expansion without the need for any patient compliance. The standard Leaf is activated periodically by the clinician in order to reload the springs, while the Leaf Self requires no re-activation at all. Both members of the series are available in either 6 or 9mm, with forces of either 450 or 900g.

LEAF self EXPANDER®



	11 mm	4 mm	∅	↔	↔	↔
			arms	body		
	450	6				
	900	6	1,5 mm	12 mm	6 mm	
	450	9				
	900	9	1,5 mm	12 mm	9 mm	

LEAF EXPANDER®



	11 mm	4 mm	∅	↔	↔	↻	activation turns
			arms	body			for maximum expansion limit
	450	6					
	900	6	1,5 mm	12 mm	6 mm	0,4 mm	30
	450	9					
	900	9	1,5 mm	12 mm	9 mm	0,4 mm	45



Swivel key and clip included in the package



Orthodontics for Kids (OK) Pediatrics:

Early treatment options are continuously a popular topic in the world of orthodontics. By developing products that correspond with this goal, LeoneAmerica hopes to meet the needs of the orthodontists and pediatric dentists working to optimize treatment for their patients. Wherever the OK Orthodontics for Kids logo is found, clinicians can rest assured that the particular product is appropriate and recommended especially for pediatric treatment. To get a copy of the new OK Orthodontics for Kids catalog, call us at (805) 487-9860.



NEW

PEDODONTIC BANDS

Designed to respond to the current needs of pediatric orthodontics and allow for early treatment of patient with mixed or deciduous teeth. Made of biomedical stainless steel in a softer medium temper, the pedodontic bands are designed for the particular anatomy and shape of the deciduous molars. These bands feature an easy fit to the pyramid shape of the primary molars, and are useful in the construction of palatal expanders or space maintainers. The laser etched identification number makes distinguishing between the ten sizes of upper or lower bands a cinch.



CODE		pkg.
E6100-00	Upper - PU sizes 1-10	5
E6500-00	Lower - PL sizes 1-10	5

E6165-96 ASSORTMENT PEDODONTIC BANDS UNIVERSAL - KIT

This kit is composed of 5 universal pedodontic bands per size for both maxillary and mandibular for a total of 100 pieces. The tray is not autoclavable.



M.A.D. SERIES LEONE

Mandibular Advancement Device (MAD) Series:

The treatment of obstructive sleep apnea is a rising need throughout the orthodontic community, and providers are presented with a variety of treatment options and appliances for their patients.

The Forward! Antisnoring is the first kit specifically engineered to fabricate the bimaxillary dorsal appliance. The kit includes upper pre-angled screws, and lower wings with an adaptable steel frame, perfect for the fabrication of the anti-snoring mechanism. While the clinician will enjoy the maximum 7mm of possible expansion, creating

In developing the Mandibular Advancement Device (MAD) line, Leone and LeoneAmerica have sought to streamline the overwhelming amount of treatment options, and offer kits for the most requested designs on the market: the bimaxillary dorsal type appliance and the plug and tube type advancer.

greater flexibility during their treatment, the lab technician will appreciate the dramatic time-saving advantages of the pre-angled screws. The screws are angled at an ideal 70°, and feature a built-in stop that ensures perfect friction and stability throughout the forward movement. Each activation generates 0.1mm advancement.



REFILLS FOR FORWARD*

Lower wings with inner steel frame



A5301-00

- Pack of:
- 1 left lower wing with steel frame
 - 1 right lower wing with steel frame

Screw 70° angulated body



A5302-00

- Pack of:
- 1 upper right screw
 - 1 upper left screw

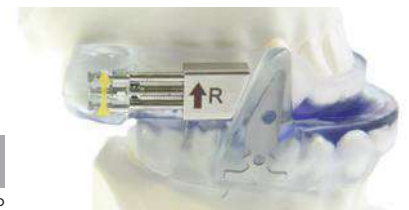
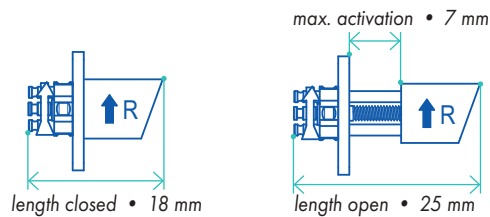

	length closed	length open	max. activation	4 activation
A5300-07	18 mm	25 mm	7 mm	0,4 mm



Emilio Pozzi, CEO of LeoneAmerica, and Gabriele Scommegna, Research and Development Director of Leone, at the exhibitor's booth during the American Academy of Dental Sleep Medicine annual show, Baltimore 2018.

MANDIBULAR REPOSITIONING DEVICES TO TREAT OBSTRUCTIVE SLEEP APNEA

The 27th American Academy of Dental Sleep Medicine Annual Meeting focused on guiding participants through a knowledge of the epidemiology and pathophysiology of obstructive sleep apnea (OSA), and the dental sleep devices available to treat its effects. LeoneAmerica and Leone both participated in this session, highlighting the functions and features of the Forward! Antisnoring Bimaxillary Dorsal Appliance and the Telescopic Advancer kits to meeting attendees in the exhibition hall. One of the primary objectives of the session was to discuss the advancements that have been made in OSA treatment, making the Forward! Antisnoring Kit a popular choice. The pre-angled screws are an innovative addition to the sleep apnea arena, providing a maximum 7mm of expansion for clinicians, and a time-saving shape for laboratory technicians.

This annual session also allowed for a valuable time of interaction with OSA treatment providers, who contributed

feedback regarding their clinical use of antisnoring devices. Ultimately, this first-hand feedback provides some of the most valuable insight possible into the uses of the product, and in the case of this particular meeting, especially the Telescopic Advancer. Based on clinical feedback received, LeoneAmerica is now pleased to offer the plug and tube component arms of the Telescopic Advancing kit for individual sale, immediately available through the recently released LeoneAmerica Laboratory Product Catalog.

The partnership between Leone and LeoneAmerica continually provides the market in North America with the best service possible, while connections with clinicians and technicians continue to add valuable insight into product applications, continuously advancing the innovation of the Leone product line. For LeoneAmerica, these collaborations were one of the greatest benefits of the 2018 American Academy of Dental Sleep Medicine Annual Meeting.

CERAMIC BRACKET



passive phase

round archwires do not get in contact with the clip so they can slide inside the slot by facilitating the process of alignment and leveling.



interactive phase

rectangular archwires used for space closure during control of rotation and torque, deform the metal clip elastically with a biomechanical gain control necessary for this stage of treatment



active phase

rectangular archwires for finishing and detailing fill completely the slot by going into active contact with the clip: that permits to take advantage of metal superelastic properties and gets the smallest movements for finishing of treatment

LeoneAmerica is pleased to reintroduce a ceramic classic in the Aqua SL (Self-Ligating). This bracket features the same well-known ceramic formulation, ensuring a crystal-clear bracket that both clinicians and patients adore. As an added feature, the reliability of the nickel-titanium door is guaranteed throughout treatment, and will permanently retain its elastic memory and shape.

Finally, the door shape allows clinician control over the passive, interactive, and active phases, as it interacts with the varying shapes and dimensions of the wires used throughout treatment.

AQUA SL self-ligating ROTH system

			torque	ang.	.022"x.030"	
			+12°	+5°	<u>1</u>	F5751-02
					<u>1</u>	F5751-03
			+8°	+9°	<u>2</u>	F5752-02
					<u>2</u>	F5752-03
			-2°	+13°	<u>3</u>	F5753-02
					<u>3</u>	F5753-03
			-7°	0°	<u>4</u>	F5749-02
					<u>4</u>	F5749-03
			-7°	0°	<u>5</u>	F5749-02
					<u>5</u>	F5749-03
			0°		<u>1</u>	F5750-05
					<u>1</u>	
			0°		<u>2</u>	F5750-05
					<u>2</u>	
			-11°	+7°	<u>3</u>	F5753-06
					<u>3</u>	F5753-07
			-17°	0°	<u>4</u>	F1044-16
					<u>4</u>	F1044-17
			-22°	0°	<u>5</u>	F1045-16
					<u>5</u>	F1045-17

Lower bicuspidis in stainless steel

AQUA SL self-ligating MBT* system

			torque	ang.	.022"x.030"	
			+17°	+4°	<u>1</u>	F5741-02
					<u>1</u>	F5741-03
			+10°	+8°	<u>2</u>	F5742-02
					<u>2</u>	F5742-03
			-7°	+8°	<u>3</u>	F5743-02
					<u>3</u>	F5743-03
			-7°	0°	<u>4</u>	F5749-02
					<u>4</u>	F5749-03
			-7°	0°	<u>5</u>	F5749-02
					<u>5</u>	F5749-03
			-6°	0°	<u>1</u>	F5740-06
					<u>1</u>	F5740-07
			-6°	0°	<u>2</u>	F5740-06
					<u>2</u>	F5740-07
			-6°	+3°	<u>3</u>	F5743-06
					<u>3</u>	F5743-07
			-12°	+2°	<u>4</u>	F1044-06
					<u>4</u>	F1044-07
			-17°	+2°	<u>5</u>	F1045-06
					<u>5</u>	F1045-07

Lower bicuspidis in stainless steel

LEONE GOTO1® (CLASS II CORRECTOR)

By Leone Technical Dept., Division of Orthodontics

Introduction

Correcting Class II Malocclusion has always represented a challenge for an orthodontist owing to the complex and multifactorial etiology (Singh et al., 2018).

The main non-surgical Class II malocclusion treatment modalities include: extraoral appliances headgear, functional appliances and fixed appliances (Bohlin et al., 2008; AAPD, 2014.).

It is remarkable that, the Guideline on Management of the Developing Dentition and Occlusion in Pediatric Dentistry reports, among the factor to consider during orthodontic treatment planning, the importance of the projected patient compliance, the anchorage requirements and the patient and parent desire. The importance of parent and patient collaborations were also highlighted in a brief literature review. As a matter of fact, the clinicians report the difficulty to achieve the desired treatment result, due to lack of patient cooperation, especially with extraoral appliance (Devincenzo, et al, 1997) and with elastics (Maltoni et al., 2014.).

The increasing demand of non-compliant treatment leads orthodontists to use more frequently, when comparing the same malocclusion severity level, inter-maxillary fixed appliances that release a predetermined amount of force to stimulate mandibular advancement. According to the literature, the most important characteristics of an ideal inter-maxillary fixed appliance are: compliance free, complete control and management of the treatment, aesthetic acceptability, resistance to breakage, avoidance of tissue irritation, short treatment time, good oral hygiene, ease of installation, low cost, and minimal inventory requirements for the orthodontist (DeVincenzo 1997; Sing et al., 2018).

In order to offer to the orthodontist all the advantages of compliance free fixed appliance for the treatment of Class II malocclusion, some years ago, Leone introduced the Class II Corrector GoTo1®, improving the mechanical features of the most famous Class II Correctors that showed substantial and well-proven clinical results (DeVincenzo, 1997). In the new 2018 version the fluidity of movement, as well as the strength of the telescopic mechanism, are improved.

Device Features

The Class II Corrector GoTo1 is a plunger assembly and a cylinder made up of medical grade stainless steel. It has an overall diameter of 3mm, and therefore, a reduced bulkiness if compared to other existing devices. The components are the plunger assembly and the cylinder (Fig. 1). In the pack is also included a ball ended wire for installation in the distal molar position.

The main improvements with respect to the previous version, include:

- Use of a tube with increased inner diameter to have a smoother movement of the inner plunger element in the tube.

- Use of a housing (Fig. 1,e) that results in an increased thickness of the tube (Fig. 1,b), enhancing the overall device resistance.

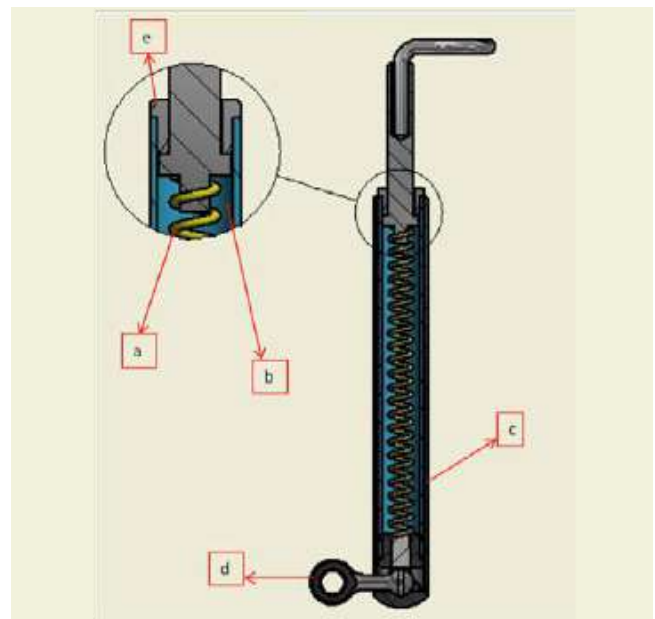

Fig. 1:
GoTo1 new version, section view. a: Ni-Ti MEMORIA® spring, b: tube of the plunger assembly, c: cylinder, d: rotating hinge ring of the cylinder and e: housing.

The active component of the GoTo1 is a Ni-Ti MEMORIA® 200g open coil spring, its super-elastic behavior allows the delivery of constant and light forces, ensuring a continuous and controlled biomechanical action that properly stimulates the mandibular growth. The Ni-Ti MEMORIA® spring is placed and sealed in the plunger system, avoiding food infiltration, and thus ensuring a good oral hygiene.

Two versions are available for the anchorage of the plunger assembly on the lower arch: anterior eyelet or anterior hook (Fig. 2).

For what concerns the upper arch, the cylinder features



Fig. 2: GoTo1 plunger system anchorage types

a rotating hinged-ring that allows a safe, easy and stable anchorage both in the mesial and the distal position to the upper molar tube. If used in the mesial position, it can be placed on a single direct-bonding tube, while if used in the distal position band a round tube are required (Fig. 3).

In order to give more anchorage flexibility, both GoTo1 with anterior eyelet or anterior hook are available in three sizes:

extra-short, short and long. In order to choose the correct GoTo1 size, the following procedure is suggested (Fig. 4).

To determine the proper size, take the distance from the upper arch anchorage point (mesial or distal respect to the molar tube) to the mid-point between lower cuspid and first bicuspid.



Fig. 4: representation of the 3 GoTo1 size available

Or, as reported in Fig. 5, using the dedicated measuring gauge** it is intuitive to figure out which, among three available sizes (25 mm extra-short, 28 mm short and 33 mm long), is the correct one.

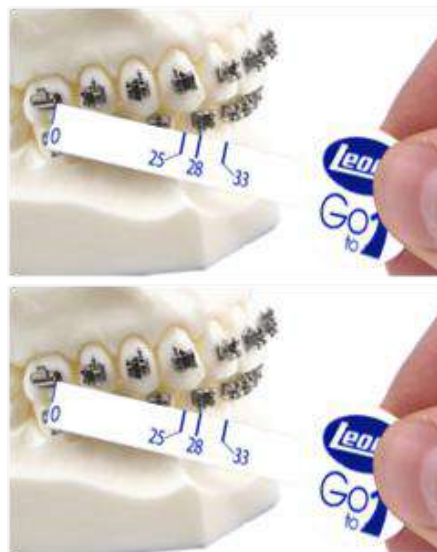

Fig. 5: example of intra-oral measurement for the correct size of GoTo1 with the GoTo1 measurement gauge. (sx: mesial support, dx: distal anchorage)

Please notice: The GoTo1 must not be assembled in the mouth completely compressed: a portion of the plunger coming out of the tube for at least 2 mm should be visible, (see Fig. 6). The measures of the length, reported in the Catalog 2018 chart and on the measuring gauge, include the 2 mm of possible additional compression.

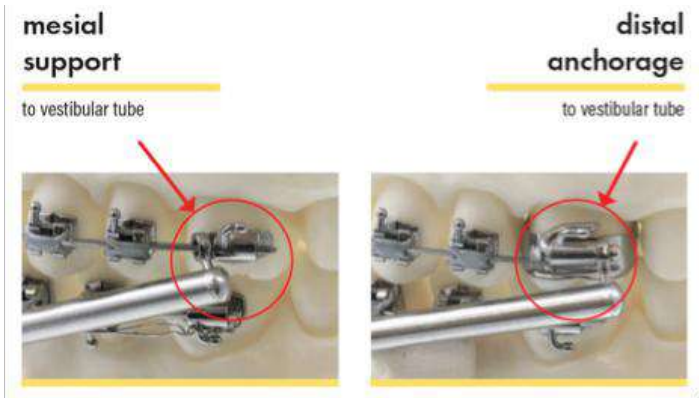

Fig. 3 example of mesial support and distal anchorage



Fig. 6: plunger portion coming out of the tube, at least 2 mm.

Instructions

The following instructions for mesial support and distal anchorage are applicable both for the GoTo1 with anterior hook and anterior eyelet. The assembling procedure is straightforward and easy to learn following the IFU included in the packaging. The assembly of GoTo1 starts from the lower archwires:

For the GoTo1 with anterior eyelet:



For the GoTo1 with anterior hook. Make sure the hook is crimped completely over the archwire!



Considering the upper arch anchorage with mesial support, both the GoTo1 with the anterior eyelet and the anterior hook are assembled in the mouth with anchoring elements (eyelet or hook and hinged ring) integrated with the device, therefore reducing the risk of patient's injuries, the chair time, and the complications for the clinicians.



For distal anchorage on the upper arch, it is necessary to use the enclosed ball-ended wire. In this case, the use of a non-integrated element is easier for the clinician and avoids excessive stress on the wire during the assembling phase, as may happen in other known Class II Correctors.



Lastly, the application of the ligature wire on the lower anchorage element (eyelet or hook):



Leone GoTo1 available range of products

To summarize, in the following chart you can find the whole range of GoTo1 available products:

WITH ANTERIOR EYELET	WITH ANTERIOR HOOK	Type	Length at full expansion (passive configuration)	Length at full compression (including 2 mm of additional compensation)	Maximum safety stroke of spring	Maximum opening allowed to prevent disassembly
M2302-00	M2301-00	EXTRA-SHORT	31 mm	25 mm	7,5 mm	48 mm*
M2302-01	M2301-01	SHORT	35 mm	28 mm	10 mm	56 mm*
M2302-02	M2301-02	LONG	40 mm	33 mm	10 mm	62 mm*

*Distance between the 2 eyelets or hooks of anchorage

Clinical cases

In the literature, it is reported that fixed appliances such as GoTo1 are used mostly in case of Class II malocclusion due to retrognathic mandible (Sing et al. 2018), on permanent dentition (from 11 y. to 16y, at the peak growth spurt) during a multi-bracket treatment, after the phase of alignment and leveling on a 0.019"x0.025" SS archwires (Karacay et al., 2006; Al-Jewair, 2014).

The following is a reported clinical case from Leone Bolletino number 94, October 2014.

A New No-Compliance Appliance for the Correction of Class II Malocclusion: Case-Report

*Original title: Un nuovo dispositivo no-compliance per la correzione di classe II: case-report
Images of the case by courtesy of Dott. Maltoni.*

Dr.ssa Manuela Maltoni - Libero professionista a Forlì e Cesena

Dr.ssa Lucia Zoli - Libero professionista a Forlì e Cesena

A 9 year-old girl presented a skeletal and dental Class II malocclusion due to a retrognathic mandible. An obvious convex profile was also characterized by an abnormal lip competence.

Considering that the Class II Malocclusion was not severe, the treatment was postponed in order to apply multi-bracket appliances on both the arches on permanent teeth. (Fig. 7-Fig. 9; Tab. 1).



Fig. 7



Fig. 8

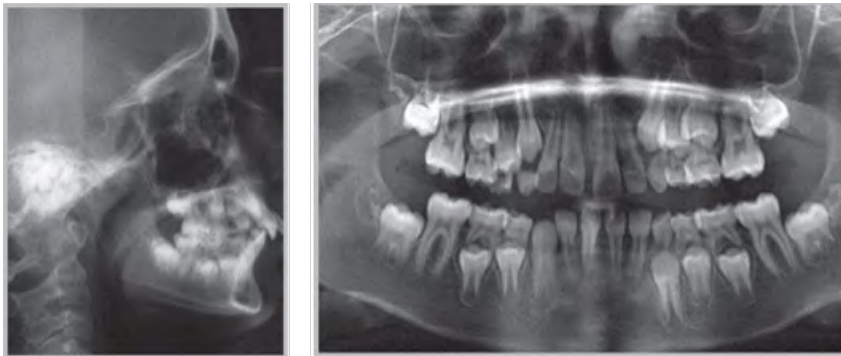

Fig. 9

Skeletal		
SN/A	82° +/- 2°	82°
SN/B	80° +/- 2°	78°
AN/B	2° +/- 2°	4°
Dental		
+1/ANS.PNS	8° +/- 3,0°	3°
ANS-PNS/GoGa	25° +/- 6°	24°
S-N/GoGa	33° +/- 2,5°	27°
Overjet (mm)		
	3,5 +/- 2,5mm	3 mm
Overbite (mm)		
	2,5 +/- 2,5mm	1 mm
U1/L1	132° +/- 6,0°	117°

Tab. 1

At 11 years old, the brackets were bonded on both the upper and the lower arch and the phase of alignment and leveling begun, in order to prepare the arches for the application of the Class II elastics (Fig. 10).



Fig. 10

Since the patient showed poor cooperation, two lateral Class II correctors were applied on .019x.025 SS (Fig. 11).



Fig. 11

The Class II corrector was removed after two months, verifying that the stability of the molars and bicuspid Class I relationship was achieved (Fig. 12).



Fig. 12

All fixed appliances were removed after 1 year and 4 months. Fig. 13-Fig. 15 and Tab. 2 show the intraoral treatment results and the comparison between the profile before and after the treatment (Fig. 16).



Fig. 13



Fig. 14

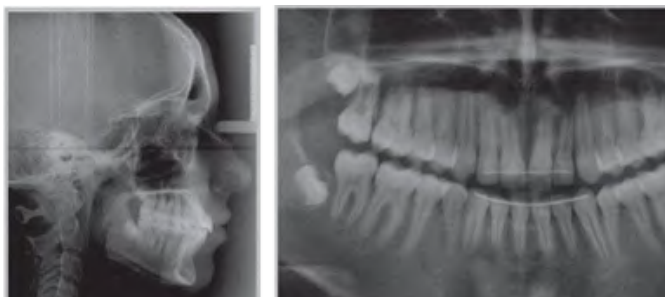

Fig. 15

Skeletal		
SN/A	82° +/- 2°	82°
SN/B	80° +/- 2°	78°
AN/B	2° +/- -2°	4°
Dental		
+1/ANS.PNS	110° +/- 6,0°	114°
1/Go.Gn	94° +/- 7°	106°
1/A.Pg (mm)	2 +/- 2mm	3 mm
Overjet (mm)	3,5 +/- 2,5mm	3 mm
Overbite (mm)	2,5 +/- 2,5mm	1 mm
UI/LI	132° +/- 6,0°	117°

Tab. 2



Fig. 16

Fig. 17 - Fig. 18 show the intraoral situation and the profile, 1 year after the end of the treatment.



Fig. 17



Fig. 18

**Patented*

***Available only in the Class II Corrector kit*

References

- Maltoni I., Santucci G., "Un nuovo dispositivo no-compliance per la correzione di classe II: case-report", Leone Bollettino, No. 93, Aprile 2014.
- Maltoni M., Zoli L.; "Un nuovo dispositivo no-compliance per la correzione di classe II: case-report", Leone Bollettino, No. 94, Ottobre 2014.
- Stromeyer E.L., Caruso J. M., DeVincenzo J., "A Cephalometric Study of the Class II Correction Effects of the Eureka Spring", Angle Orthodontist, Vol 72, No 3, 2002.
- Bohlin, Robert and Andreas Bousios. "Treatment alternatives for patients with Class II division 1 malocclusion." Conference proceedings (2008).
- Guideline on Management of the Developing Dentition and Occlusion in Pediatric Dentistry, American Academy Of Pediatric Dentistry, last revision 2014.
- Karacay S., Akin E., Olmez H., Gurton A. U., Sagdic D, "Forsus Nitinol Flat Spring and Jasper Jumper Corrections of Class II division 1 Malocclusions", Angle Orthodontist, Vol 76, No 4, 2006.

CLASS II CORRECTOR (GOTO1®)



NEW

The non-compliance device for Class II correction. The small sizes of the device all for optimal patient comfort while the constant and light force delivered by the spring MEMORIA 200g, located inside the plunger, stimulates the mandibular advancement. In this new version, the fluidity of movement and the strength of the telescopic mechanism are improved. The packages include all the needed parts for the application of a bilateral correction device.

Available in three lengths with both mesial and distal fitting to the upper molar tube, for a total of six possible positions in the mouth. When used in the mesial position, it can be placed on a single direct-bonding tube, without the need for a band of round tube.

mesial support

to vestibular tube

distal anchorage

to vestibular tube

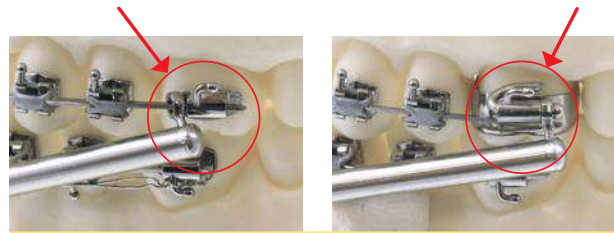

Two possible positions

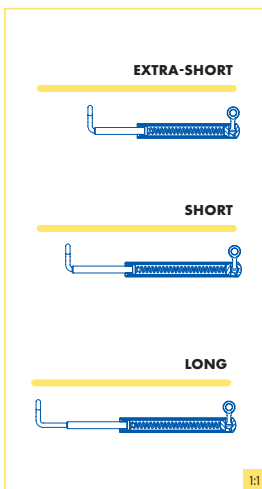

1 with anterior eyelet

2 with anterior hook

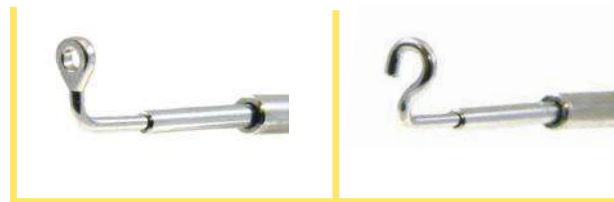

Available in two versions

WITH ANTERIOR EYELET	WITH ANTERIOR HOOK	Type	Length at full expansion (passive configuration)	Length at full compression (including 2 mm of additional compensation)	Maximum safety stroke of spring	Maximum opening allowed to prevent disassembly
M2302-00	M2301-00	EXTRA-SHORT	31 mm	25 mm	7,5 mm	48 mm*
M2302-01	M2301-01	SHORT	35 mm	28 mm	10 mm	56 mm*
M2302-02	M2301-02	LONG	40 mm	33 mm	10 mm	62 mm*

*Distance between the 2 eyelets or hooks of anchorage

WHY CHOOSE US



When you choose a LeoLab, you are choosing years of specialized orthodontic experience, combined with the expertise and technical ability that consistently produce appliances of the highest quality. Even better, with LeoLab locations stretching from coast to coast, you are likely to find a laboratory partner right in your backyard.

Research, innovation, and quality: these are the collaborative goals of LeoneAmerica and LeoLab USA.

Splints



Splints can be used for a variety of treatment considerations, including finishing, intrusion, bruxing, and muscle or joint disorders. These appliances can be fabricated from a variety of material options, including hard acrylic, thermoplastic acrylic, or hard/soft pressure-formed plastic, dependent on patient needs.

Removable



Removable appliances can produce dental arch expansion, move single, or groups of teeth, correct deviations or create space for erupting teeth. The incorporation of Leone screws can help create removable expanders, while the addition of hooks, pontics, habit cribs, or bite plates can help customize these appliances by patient need.

Retainers



Retainers are used to maintain a finished case, whereas active retainers can be used for minor tooth movement and finishing. With the use of Leone acrylics, retainers can feature bright colors, glitters, or custom designs.

Functional



Functional appliances utilize the muscle action of the patient to produce orthodontic forces for the correction of class II and class III malocclusions. These appliances are available in a multitude of configurations and types, including: Herbst, Frankel, Twin Block, Activators, and Bionators.

Fixed



Fixed appliances are attached to the tooth structure and can be used for orthodontic or orthopedic purposes, including expansion, distalization, habit breaking, and space maintenance.

Sleep Apnea



Although sleep apnea may be caused by a variety of conditions, a common cause is the posterior displacement of the tongue during sleep. LeoneAmerica is proud to carry two of the most popular sleep apnea devices, the bimaxillary dorsal type and plug and tube type. Each appliance is designed to position the mandible forward to open the patient's airway and is specifically tailored to their anatomy for maximum comfort and fit.



Digital Services

Digital services have changed with the face of orthodontics. With today's state-of-the-art technology and the advancement of 3D printing, digital services can save time while improving accuracy and precision in fabricating orthodontic appliances.

LEONE CERTIFIED LABORATORIES

Research, innovation, and quality: these are the goals of LeoLab USA. Learn more at www.leolabusa.com



COTTONWOOD LABORATORIES

Murray, UT 84107
phone 801-904-2006
office@cottonwoodlabs.com



DURINGER ORTHODONTIC LABORATORY

Alameda, CA 94502
phone 510-522-2485
info@duringerortholab.com



EAST ORTHODONTIC LABORATORY

Albuquerque, NM 87120
phone 505-899-4344
eastortholab@comcast.net



EUROPEAN ORTHODONTIC LABORATORY, INC.

Cumming, GA 30041
phone 678-455-3613
info@europeanortholab.com



EXCEL ORTHODONICS, INC

Tigard, OR 97224
phone 971-249-0261
excel@excelorthodontics.com



OLYMPIC ORTHODONTIC LABORATORY, INC.

Woodinville, WA 98072
phone 425-806-9194
info@olyortholab.com



ORTHODENT LAB

Williamsville, NY 14221
phone 716-839-1900
info@odlortho.com



PERFECT FINISH ORTHO LAB, INC.

Hackettstown, NJ 07840
phone 908-852-3035
info@perfectfinishortho.net



QC ORTHODONTICS LAB, INC.

Fuquay-Varina, NC 27526
phone 919-577-2250
info@qcortho.com



ROQUE ORTHODONTIC LABORATORIES, INC.

Foothill Ranch, CA 92610
phone 949-581-9711
info@roqueortholab.com

WHERE TO FIND US



WWW.LEONEAMERICA.COM

LeoneAmerica Dental Products, Inc is delighted to introduce our upgraded website, www.leoneamerica.com. Products can be searched by orthodontics, pediatrics, or sleep apnea specialties, making the task of finding the perfect treatment solution even easier. We are so pleased to introduce this site as an interactive and useful tool for our clinical and laboratory customers.



LeoLab USA

Certified LeoLab partners work closely with LeoneAmerica to bring you the best of research, innovation, and quality. The collaboration between specialized orthodontic experience and top-tier orthodontic manufacturing help to bring together some of the most precise orthodontic appliances on the market today.

— ASSOCIATION OF —
**ORTHODONTIC
LABORATORY
PROFESSIONALS**

[ASSOCIATION OF ORTHODONTIC LABORATORY PROFESSIONALS](#)

LeoneAmerica Dental Products, Inc is proud to announce itself as a corporate sponsor of the Association of Orthodontic Laboratory Professionals. This collaborative group focuses on fostering relationships between orthodontic professionals, and moving the field of orthodontics together as a whole.



[THROUGH TRUSTED SELLERS](#)

Leone products are available through a number of trusted dealers throughout the United States. For more information on how to purchase Leone products, please call us at (805) 487-9860 or visit us online at www.leoneamerica.com

BRINGING IT ALL TOGETHER

2018



Leone and LeoneAmerica booth at the 2018 AAO in Washington DC

LEONEAMERICA, LEONE, AND LEOLAB USA ALL ATTEND AAO DC 2018

LeoneAmerica, Leone, and LeoLab USA were all pleased to participate in the 2018 American Association of Orthodontics annual session held in Washington DC. The three associates shared the same premier booth, highlighting their collaboration, and shared expertise. In one convenient space, meeting attendees could learn from Leone the manufacturing and technical details for their favorite products, work with their LeoneAmerica sales staff to discover new additions to the product line, and see real-world examples of applications through the LeoLab USA appliances. This integrated approach continues to help best serve LeoneAmerica customers throughout North America.

Meeting highlights included the presentation on the Leone MEMORIA Leaf Spring Activated Expander, and its applications for a variety of treatment plans.



LEONEAMERICA



Contact Info:

(805) 487-9860

(800) 235-4639

FAX (805) 834-0124

info@leoneamerica.com

www.leoneamerica.com

1250 Stellar Dr

Oxnard, CA 93033-2404

LeoneAmerica is the exclusive distributor of Leone Orthodontic products in the United States, Canada, and Puerto Rico.



Orthodontics and Implantology

LEONEAMERICA
ORTHONEWS

1250 Stellar Drive
Oxnard, CA 93033-2404
805-487-9860



Navigating the Tides

PCSO 82nd
ANNUAL SESSION



MONTEREY, CA
OCTOBER 11-14, 2018
MONTEREY CONFERENCE
CENTER
WWW.PCSORTHO.ORG

VISIT US AT THE LEONEAMERICA
BOOTH #316



NESO 2018
Mohegan Sun
November 2-3, 2018

NESO ANNUAL SESSION 2018
UNCASVILLE, CT
NOVEMBER 2-3, 2018
MOHEGAN SUN
WWW.NESO.ORG



Winter Conference

JW Marriott Marco Island Beach Resort | Marco Island, Florida
January 25-27, 2019

MARCO ISLAND, FL | JANUARY 25-27, 2019
JW MARRIOTT MARCO ISLAND
WWW.AAOINFO.ORG/MEETINGS